



## Fitness • Essentials



m<sup>2</sup>  
15

0.9

14+

1

3

### Sit Up

8078924 Black/Lime Green

8078932 Titanium Grey/Lime Green

CC Cast In Place

★ 460 x 340

For more details please visit our website:  
[www.tgogc.com](http://www.tgogc.com)

Strengthens abdominal muscles and provides core stability, which helps support and protect internal organs and aids in breathing.

It can be used for a wide variety of sit-ups and abdominal crunch exercises, as well as seated leg raise exercises. The Sit Up is great value and very low maintenance.



## Fitness Values

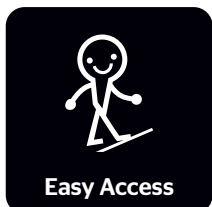

Easy Access



Inclusive



Physical Challenge

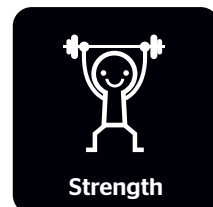

Strength





## Fitness • Essentials

### Sit Up

Age Range	14+
Users	1
Assembly Time (hrs)	3
Length (m)	1.60
Width (m)	0.40
Height (m)	0.85
Net Weight (kg)	35
Fall Height (m)	0.9
Movement Space L (m)	4.60
Movement Space W (m)	3.40
Area of movement (m <sup>2</sup> )	15

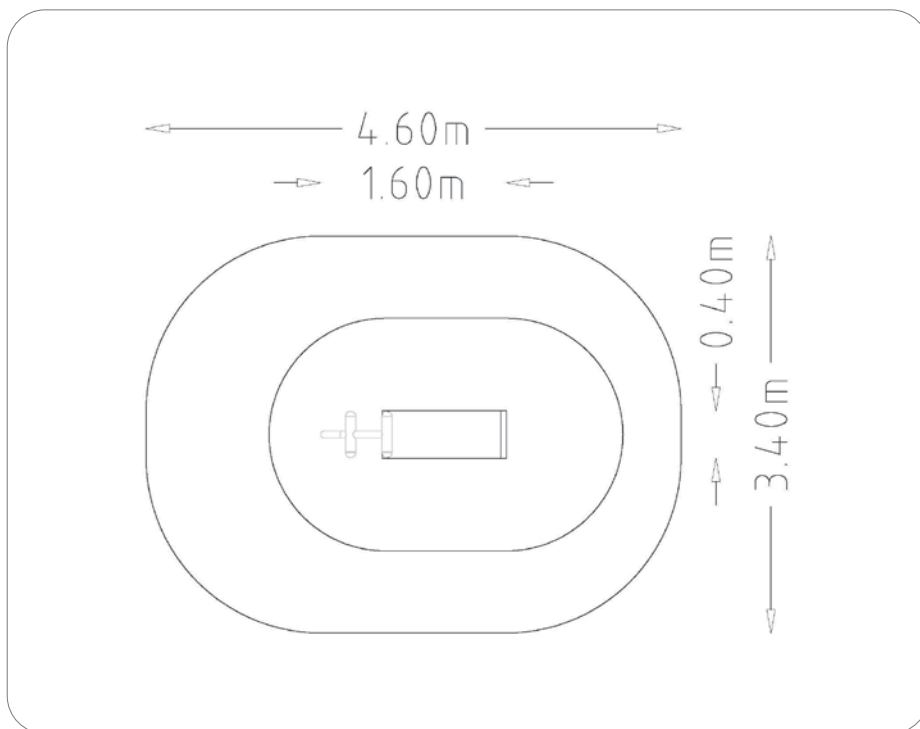

## Technical Specification

Product designed and certified to EN 16630. Structural steel tubes fabricated to form a fully welded framework.

Perforated steel sheet fabricated to form a fully welded bench.

All steel parts are finished with 'HAGS Coat' antimicrobial powder coating system, as standard.

Generally, bolts are special stainless steel tamper resisting button heads.

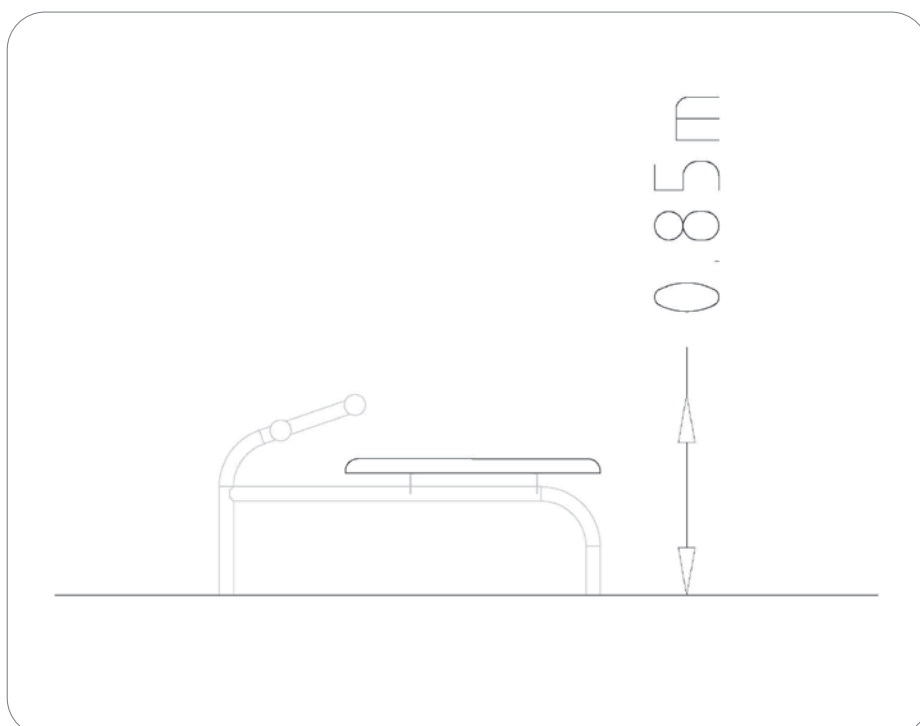

Assembly time



Recommended age



Accessible



Free height of fall  
EN 16630



Space needed



Area of movement  
EN 16630



No. of  
Users