



Fitness • Plus



Parallel Rails



8078972 Black/Lime Green 8054998



Titanium Grey/Lime Green



Cast In Place



3.54 x 4.75

For more details please visit our website:
www.tgoc.com

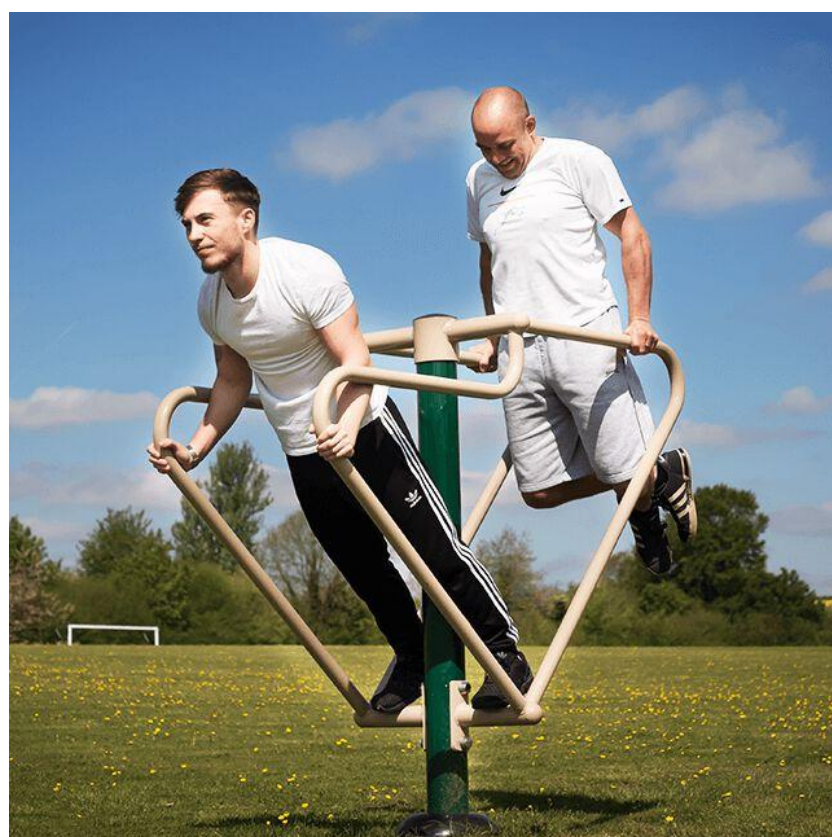

Designed for two users at a time, this unit will be popular amongst those looking to build up their upper body strength.

A great piece of fitness equipment to strengthen triceps and core muscles. The parallel rails is great value and very low maintenance.



Fitness Values

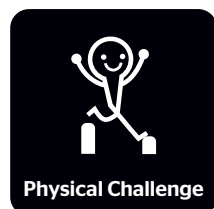



Fitness • Plus

Parallel Rails

Age Range	14+
Users	2
Assembly Time (hrs)	3
Length (m)	1.75
Width (m)	54
Height (m)	1.74
Net Weight (kg)	159
Fall Height (m)	1.46
Movement Space L (m)	4.75
Movement Space W (m)	3.54
Area of movement (m ²)	15

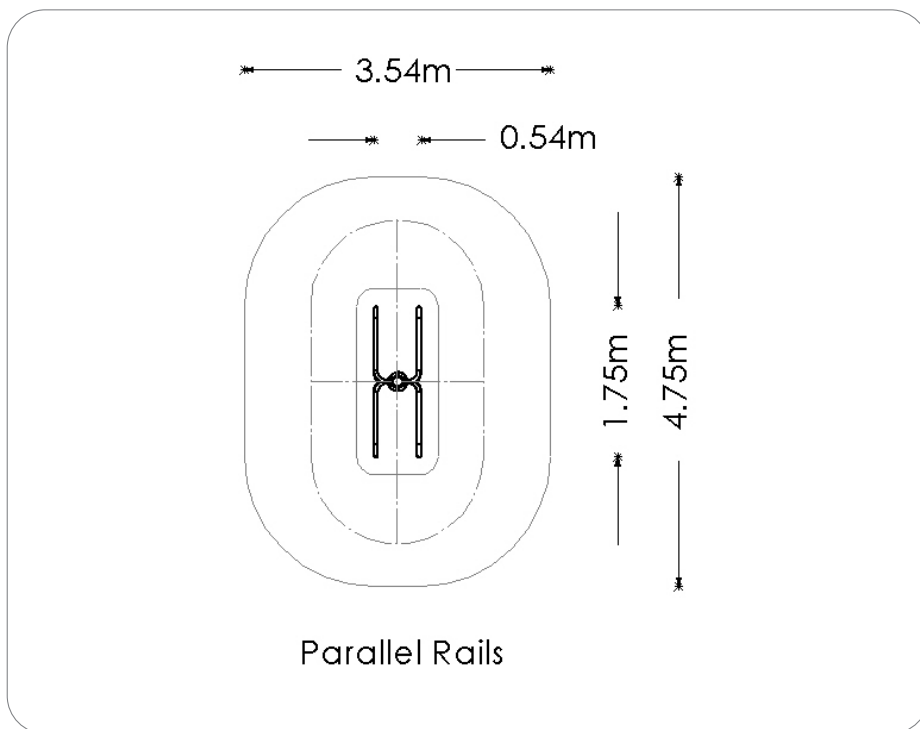

Technical Specification

Product designed and certified to EN 16630. Structural steel tubes fabricated to form a fully welded framework.

All steel parts are finished with 'HAGS Coat' antimicrobial powder coating system, as standard.

Generally, bolts are special stainless steel tamper resisting button heads.

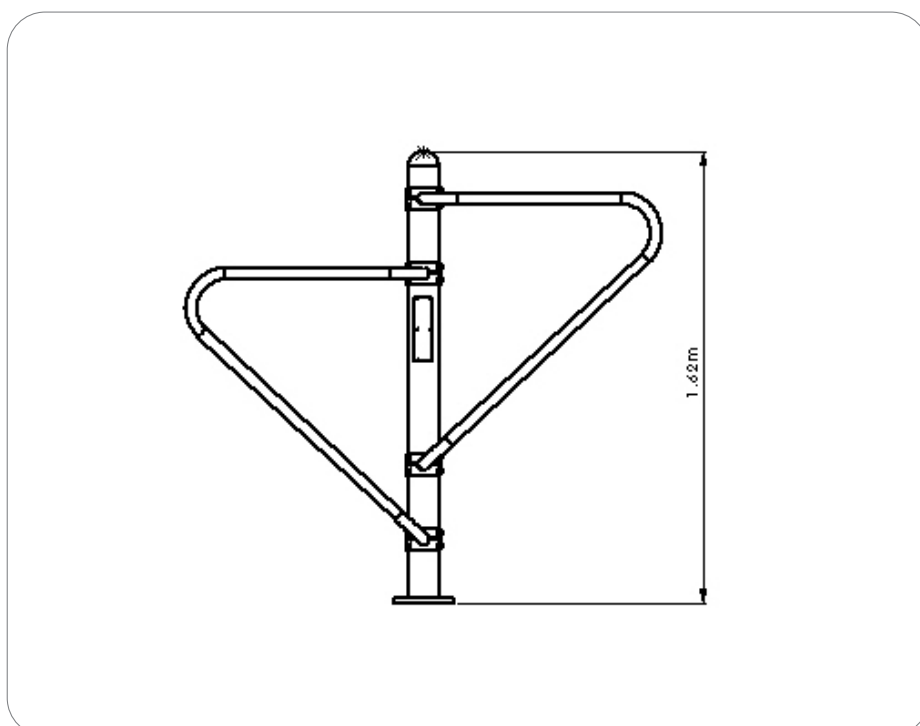

Assembly time



Recommended age



Accessible



Free height of fall
EN 16630



Space needed



Area of movement
EN 16630



No. of
Users