



Powered by **tgo**

Fitness • Plus



m²
17

<0.6

14+

1

3

Air Skier

8079038 Black/Lime Green

8079042 Titanium Grey/Lime Green

CC Cast In Place

★ 4.25 x 4.55

For more details please visit our website: www.hags.com

Helps to tone the waist, hip and thigh muscles and improve general cardiovascular fitness, balance and coordination.

Gradually increase the speed and intensity to make the exercise more challenging. The air skier allows the user to perform gentle exercises with no strain on the joints and is ideal for low impact workouts or warm-ups.



Fitness Values





Fitness • Plus

Air Skier

Age Range	14+
Users	1
Assembly Time (hrs)	3
Length (m)	1.25
Width (m)	0.95
Height (m)	1.55
Net Weight (kg)	150
Fall Height (m)	<0.6
Movement Space L (m)	4.25
Movement Space W (m)	4.55
Area of movement (m ²)	17

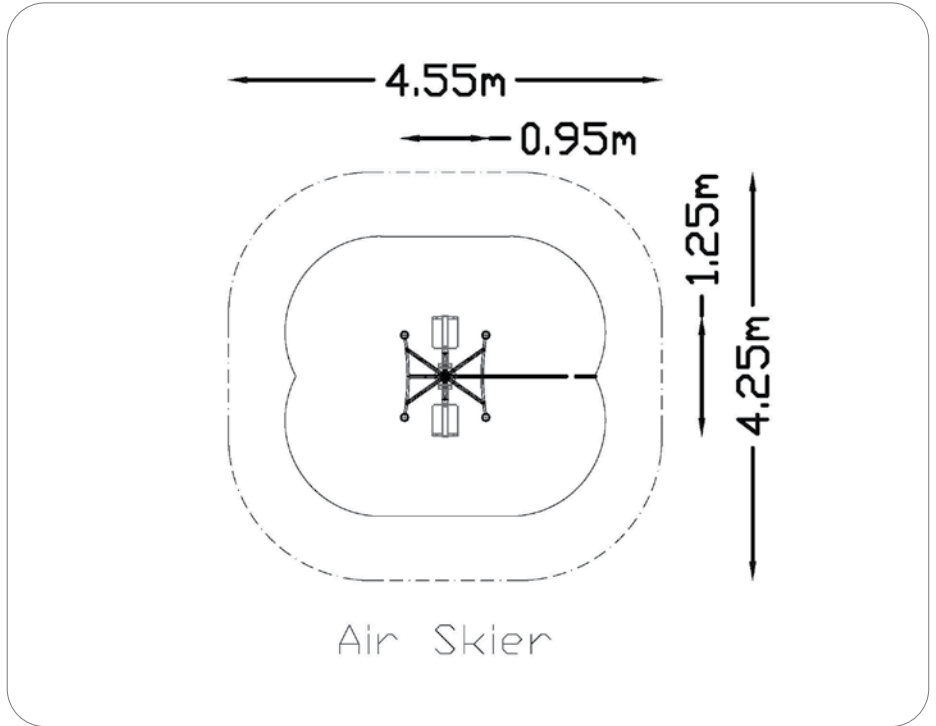

Technical Specification

Product designed and certified to EN 16630. Structural steel tubes fabricated to form a fully welded framework.

Sealed for life bearings, Internal motion controlling buffer stops and Aluminium foot plates.

All steel parts are finished with 'HAGS Coat' antimicrobial powder coating system, as standard. Generally, bolts are special stainless steel tamper resisting button heads.

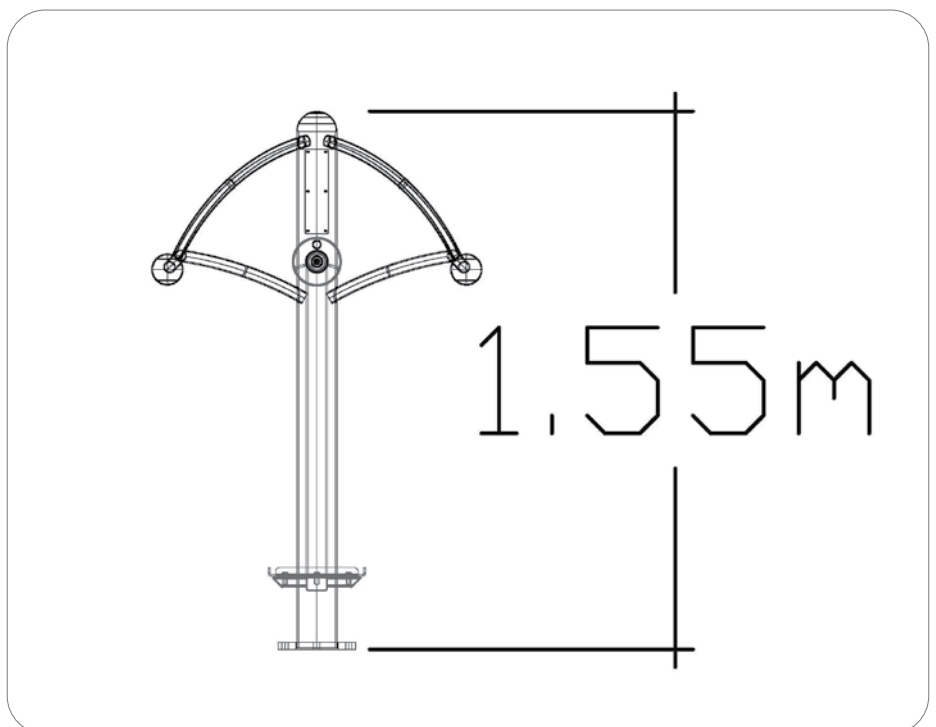

Assembly time	Recommended age	Accessible	Free height of fall EN 16630	Space needed	Area of movement EN 16630	No. of Users